



T-computers and the Origins of Time in the Brain

Scott M. Hitchcock^{1,2}

Abstract

Recent research has *identified the components* of the brain that appear to time label information from observed sensory events, store the labeled information in memory and then using the time labels for two or more events to compute their time differences, time intervals, elapsed times or 'lifetimes'. Time differences are the basis of the 'time' numbers we read from clocks and compute in our brains. Time is our map of change. Maps are abstractions of information and can be used to construct useful devices such as space-time. A general time computer or T-computer model is outlined that shows how observed signals can be processed into time labeled information states infostates by our instruments or our brains. The observer can communicate the 'time' computed for observed events using consciousness and language signals to drive sound signals in the vocal cords for instance. The 'problem of time' is near a realistic solution now that the brain's T-computer has been identified. The brain is the 'local' creator of time, space, and space-time as our special maps of the reality we 'observe' and participate in.

Key Words: T-Computers, Information

NeuroQuantology 2003; 4: 393-403

¹ Other papers by Scott M. Hitchcock are at <http://www.msu.edu/~hitchco4/>. Correspondence hitchco4@pilot.msu.edu.

² This version of the paper was slightly revised on January 5, 2003, by the deletion of the J. Barbour reference. It was replaced with J. B. Priestley's 1964 book "*Man and Time*" which I only found just recently. This book pre-dates Barbour's ideas about *change as the source of time* and I felt that I should refer to the earlier source for historical correctness. There may be even earlier references that I have not yet found. I have said in my earlier papers "No change means no time". I arrived at this while completely unaware of both Priestley's work in 1964 and Barbour's 1999 book "The End of Time" and his web page. If some of my other ideas are inadvertent reinventions of other people's work, I would appreciate references from the reader. Please look at the extensive references in my earlier papers before contacting me since many other people's papers are *implicitly referred to* via the references to my own earlier papers I use in this paper.

“Why is the flow of psychological time identical with the direction of increasing entropy? The answer is simple: Man is part of nature, and his memory is a registering instrument subject to the laws of information theory. The increase of information defines the direction of subjective time. Yesterday's experiences are registered in our memory, those of tomorrow are not, and they cannot be registered before tomorrow has become today. The time of our experience is the time which manifests itself through a registering instrument. It is not a human prerogative to define a flow of time; every registering instrument does the same. What we call the time direction, the direction of becoming, is a relation between a registering instrument and its environment; and the statistical isotropy of the universe guarantees that this relation is the same for all such instruments, including human memory.”

Hans Reichenbach

INTRODUCTION

What is Time? *Time* is a form of information (a ‘label’, ‘number’, or ‘dimension’, etc.) we have invented to *quantify* and *measure* (usually a ‘number’) *changes* in the things that fill the world around us as well as the life processes within us.

The time labeled information state is a new state of mind that is a sum of observed sensory information combined with a time label. One can think of this as a ‘word’ of ‘**a**’ bits of observed information combined with ‘**b**’ bits of time labeling information forming a ‘word’ or infostate, **I**, at a time, **t**, of $\mathbf{a} + \mathbf{b} = \mathbf{I}_t$ total bits that can be ‘perceived’ and compared with other time labeled infostates as well as ‘stored’ in accessible sequential memory locations. This infostate is only one of many in a sequence that characterize evolving configuration changes of the observed phenomena around us. *Time* is a construction of our brains used to organize sequential patterns of detected information from our senses. *How* we create time is the key to understanding the way we use

Time is a form of information that represents a measure of change. The real 'problem of time' is about how we compute 'time' and build time and space maps using our instruments and our brains.

time to create *maps* of change and build scientific models of the universe. We are now capable of examining our use of ‘time’ as a dimension. The brains’ builds maps of changing patterns in order to extrapolate how these patterns might evolve. These maps of reality are formalized into physical ‘laws’ using mathematical structures such as space-time. ‘Time’ is the result of our brain’s need to detect patterns of change for our own survival. Time is but also for understanding the beauty of all life and inanimate things as they change and evolve through a process of creating new forms and structures. Time mapping processes in our brains are traceable back to the DNA that builds our bodies and runs the biological clocks of life.

Let us look at Time as a form of *information* Hitchcock 2002, Hitchcock 2001, Hitchcock 2000, Hitchcock 1999) that *represents measures of change*. J. B. Priestley said

“No change, then, no Time” (Priestley 1964) This means that ‘change’ is a necessary condition for the *creation* and *computation* of time as well as the use of time as a ‘dimension’. ‘Change’ in the shape, contents, energies, and other physical and chemical properties of substances (matter) forming systems spread throughout the universe is observed as signals originating in, or modified by, the reconfigurations of these islands of matter. We exist as active evolving complex systems of matter on the sea of the vacuum. The distribution of is used to construct a map of the vacuum that we call ‘space’. ‘Forces’ such as the strong, electromagnetic, weak, and gravitational interactions drive the reconfigurations. The real ‘problem of time’ is about how we compute ‘time’ and build time and space maps using our instruments and our brains.

The recent work of Rao, Mayer, and Harrington (Rao 2001) has isolated the physical components of the T-computer in the Brain; “Early cortical activation associated with encoding of time intervals was observed in the right inferior parietal cortex and bilateral premotor cortex, implicating these systems in attention and temporary maintenance of intervals. Late activation in the right dorsolateral prefrontal cortex emerged during comparison of time intervals.”

Exactly how information is processed into ‘time’ by these components at the quantum level is still an open question. The components they have identified are at this point still ‘black boxes’ that take an input and generate an output. The deeper cellular and sub-cellular computational and information processing activities are as yet to be identified. The identification and functional properties of these components is still important since they act as computational systems that are identified in the T-computer model. The relationship of these brain areas to the parts of a T-computer will be discussed later in this paper. We will also look at the role of the T-computer and consciousness. First we want to describe the T-computer model and outline how time labels events, calculates time intervals, differences, and ‘lifetimes’. Once ‘times’ are identified with events we have the basis for creating time as a dimension used in maps like space-time and how ‘arrows of time’ are created and identified with the evolutionary processes of the things that make up our universe.

T-COMPUTERS AND TIME CREATION

T-computers (Hitchcock 2002, Hitchcock 2001, Hitchcock 2000, Hitchcock 1999) are essential to our maps of reality. They are used to create ordered sets of time labeled *observed* events or time calibrated internal thought processes whose ‘linear’ or non-linear causal time ordering may be the location of the infostates representing the events in memory and their contents. An *infostate* of a system is the set of configuration observables for that system along with the *information content* usually expressed as the wavefunction for the system. Information originates in quantum system and is processed as quantum or classical states of the neural networks of our brains. This is one of the places where the ‘neural’ *merges* with the ‘quanta’ of ‘change’.

Time is a form of information computed by a T-computer (see Fig. 1). Signals created during a configuration change in a system, can carry information to the detectors of the observer. The detectors convert the signal into another signal that can be sent to the T-computer and other information processing networks. The signals deposit information

T-computers used to create ordered sets of time labeled *observed* events or time calibrated internal thought processes whose 'linear' or non-linear causal time ordering may be the location of the infostates representing the events in memory and their contents.

in each ode or logic gate of the network by the creation of a reconfiguration infostate there. The gate can then act on the infostate to produce anew one to send along the network or store it as a memory of the event information brought to the observer by the original signal. The T-computer time labels the infostate in the first stage, then stored then in a working memory. The working memory can be addressed by the T-computers second stage, which can *retrieve* or

copy infostates from memory for two events and compare (subtract) their time labels in order to calculate elapsed 'time' between the events. The stored infostates can be the 'start' and 'stop' signals for a single event or the time labels for two different events. In either case it is the 'time difference' that is the output of the T-computer. This is the *time* we normally associate with the coordinates of a conventional event located by one dimension of time and three of space in space-time diagrams.

Let's examine how *time-independent* information flow (sequential 'changes' of states of network components) through a T-computer starting with signal detection from 'observed' events processed in *parallel* with coincident 'clock' signals moves is an serial path to the T-computers 'time' computer ending with a 'time' output. This 'time' number can now be processed into the 'time' of space-time.

STANDARD SIGNALS FROM 'CLOCKS'

In order to create time we begin by pairing a signal representing a reference event acting as a standard and a signal from the observed event representing the information we want to 'time label'. Since the general idea of a clock is something that already 'measures' time, for the purposes of this paper we will *define a clock as any system that produces signals that can be used to compute time by a process of signal mapping of the clock signal to another signal that is to be 'time labeled' by a T-computer*. In this way we can think of a clock as a system that 'changes' in such a way as to produce signals without any explicit or implicit *measurement* of 'time'.

Next we address the nature of a clock as a standard signal producing system that emits calibration signals in a repeating, regular, and precise way. The atomic clock is a system in which the repeating of signals is driven by classical electronics operating on a quantum system. Energy is provided in order to reset the quantum system after it has

decayed in a time-independent 'lifetime' as a function of the systems composition and stability. This controls the system in a repeatable way.

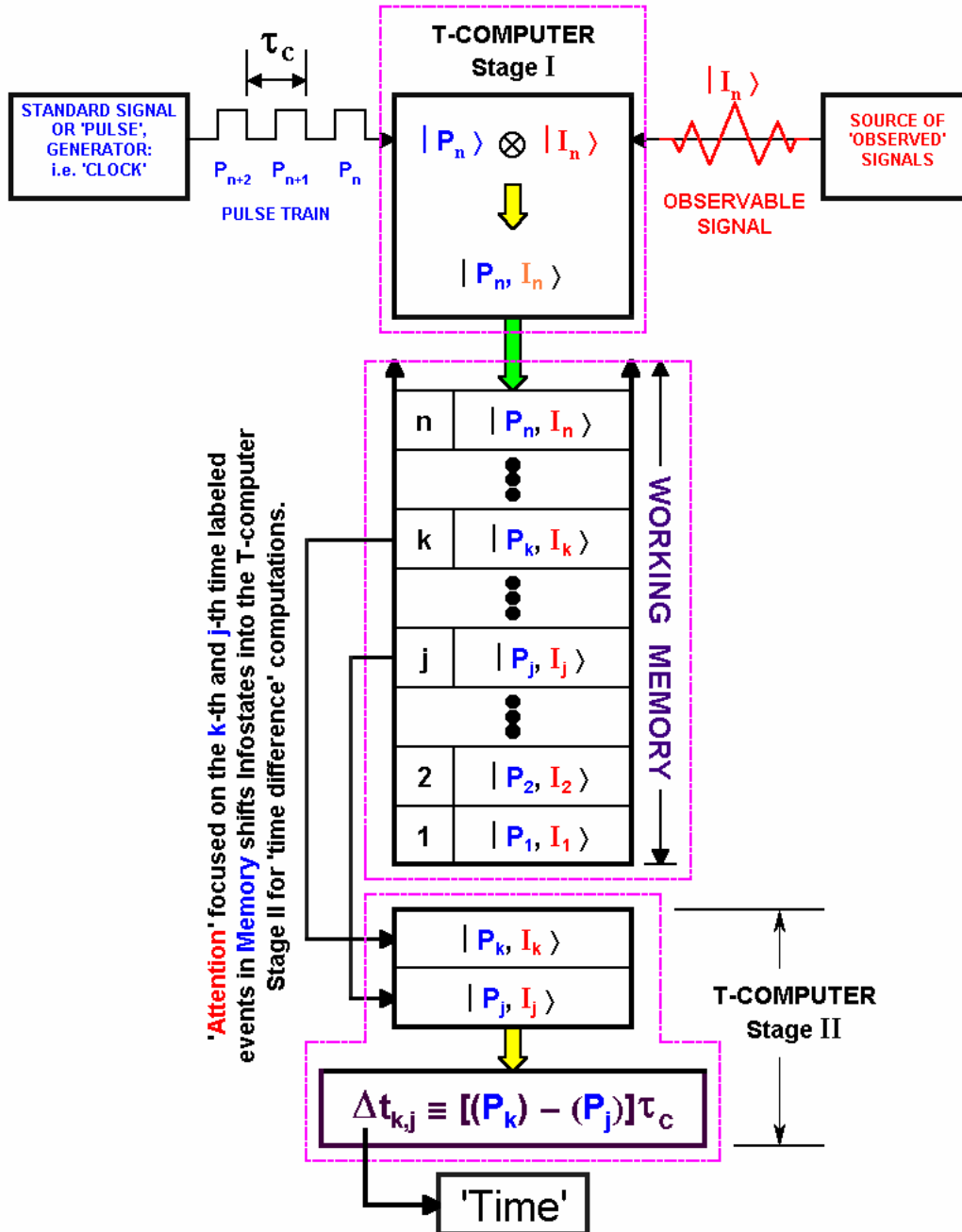

Figure 1. The T-computer.

The ‘dimensions’ of the *units* of ‘time’ we give to the ‘lifetime’ of a state come from *Planck’s constant*, \hbar , which acts a dimensional conversion factor transforming the time-independent changes and information in the quantum systems reconfiguration process on the right hand of the equation below to the ‘time’ on the left.

$$\tau = \hbar / \Gamma$$

On the right we have the ‘decay rate’ Γ (Veltman 1995). It curiously does not have ‘units’ of time but rather *energy*. Energy changes involved in the decay process are controlled by the fundamental forces between the particles that make up the quantum system and their geometric instability. This causes the system to decay in a finite lifetime as compared with another system that decays in a ‘standard’ lifetime such as the atoms in an atomic clock. The dimension of ‘time’ on the left comes from Planck’s constant which encodes the relationship between two quantum systems that provides the information used to define time as a ‘relational’ concept relative to at least two changing systems. This is discussed in more detail in (Hitchcock 2001, Hitchcock 2000, Hitchcock 1999).

We will define a **clock** as any system that produces signals that can be used to compute time by a process of signal mapping of the clock signal to another signal that is to be ‘time labeled’ by a T-computer

While one may say that the units of energy when reduced to fundamental observables has ‘time’ in it, one can measure the energies involved in the reconfiguration changes as numbers such as positions of line spectra on a detector array without considering time. If one had no concept of time one could still measure the energies of different wavelengths of light!

In figure 1 the standard signal generator on the upper left could be an ‘atomic clock’ or other ‘clock’ device that creates signals in a regular way that when paired with observed signals can be used to define time as ‘time label differences’.

SIGNALS FROM ‘OBSERVED’ SYSTEMS

All unstable systems in the universe produce information when they undergo a ‘change’ to a more stable configuration. At the quantum level we see this in the emission of light when electrons jump to lower energy configurations. The light emitted by these atoms are signal that carry information about the quantum structure of the electronic orbitals. Spectroscopy gave us the information to build the quantum model of these systems by providing information that was carried identically with the photons. Signals can be the result of reconfiguration in many body systems acting collectively. The changes in the collective excitations of these systems can result in photons, phonons, excitons, and many other ‘quantum’ signals. They can also give rise to mesoscopic and macroscopic signals such as electromagnetic ‘waves’ and sound waves in the limit of many quantum signals acting collectively as a ‘classical’ object.

The signals may also be chemical transmitters such as those involved in biological

detection and information processing systems. Complex causal networks can be composed of hierarchical *plateaus of complexity* or *POCs* from atoms to molecules to macromolecules to organelles and cell nuclei to cell membranes, to cells and groups of cells acting collectively as organs and organs acting collectively to form organisms. At each level, ‘changes’ in configurations can produce information and signals represented by, $[I_n \tilde{n}]$ that can be time labeled by a standard clock by paring it with a *countable* clock pulse, $[P_n \tilde{n}]$ in figure 1. This is the information detected by our senses and their extensions in the form of instruments.

T-COMPUTER STAGE I COMPUTATIONS

This is where ‘time labeling’ of detected information begins. Modeling this process is now possible due to the development of quantum information processing methodology (Nielsen 2000) that allows us to identify physical information flow in causal networks using quantum computation.

The incoming signal from the standard clock and the target signal (i.e. the observed signal from the source) are detected and converted into a configuration of the detectors called an *infostate* containing the information deposited in the detectors that represents some or all of the observables involved in the creations of their respective signals and sources. Infostates can be acted on by the subsequent logic of the nodes or gates in the causal network forming the time computer in much the same way that CCD camera images of objects can be ‘time labeled’ and uploaded into a computer for image processing.

The two signals can be thought of a quantum or classical words whose individual entries are quantum or classical bits as in quantum or conventional computers. If each word representing the clock and observed signals and their information content is put together to form a composite quantum or classical word, then this *concatenation* process is identified with the ‘direct tensor product’, $\tilde{\Delta}$, as opposed to summation $+$. This is because the new state formed by the two infostates is the collective excitation state of a ‘composite’ many-body quantum system *not* the linear superposition of states identified with the wavefunction for a single isolated system such as that of a hydrogen atom. The composite infostate is one with both infostates *concatenated* together into a larger infostate by the T-computer Stage I detectors and associated processing logic. The new infostate is:

$$[P_n, I_n \tilde{n}] = [P_n \tilde{n}] \tilde{\Delta} [I_n \tilde{n}]$$

At this point P_n is the n^{th} pulse number as counted by the T-computer in the detection sampling ‘window’ closest to the n^{th} observed signal infostate detection ‘event’ where the information content of this signal is I_n . The observed information now has a ‘*pre-time label*’, P_n , whose conversion into conventional *event times* used in space-time maps will be done in the T-computer Stage II.

In the case of the brain, the detectors may be essentially separate from the

T-computer Stages I. The detectors, such as eyes, send the information extracted by a signal conversion event (sometimes erroneously referred to as the *collapse* of the photon wavefunction when in fact the photon is converted to a retinal infostate by the processing of it into a collective excitation emitted as a nerve impulse) via the *optic pathway* to the *T-computer Stage I* in the brain.

WORKING MEMORY

This is the physical system, accessible, that stores the '*pre-time labeled*' infostates generated in the T-computer Stage I. It is accessible by the *attention* mechanism that selects given infostates for further information processing by the T-computer Stage II leading to the *time difference* computations needed for the construction of 'time' as a *dimension* with *direction*.

T-COMPUTER STAGE II COMPUTATIONS

The *attention* of the observer identifies and grabs the infostates for two events from the working memory in order to find a *time difference* between their *pre-time labels*. It loads them into a 'comparator' to compute the difference between the *pre-time labels* for the two infostates in order to compute $\Delta t =$ '*conventional time*'. A *pre-calculation* can also occur in which the two events are first compared to some defined $t = 0$ or t_0 reference event infostate allowing the assignment of a conventional time label to each event in working memory whose meaning is the elapsed time with respect to a standard event. The time difference between the two events is the difference between the newly assigned final *time labels*. The time difference can also be computed directly without the t_0 reference event!

Either way the pre-time labeled events can be computed into conventional time labeled events with a 'time' number associated with each. These time numbers are what we usually call the event time but they have to be computed first by a signal mapping and labeling process in the T-computer before they can surface in consciousness as *the time something happened*.

Once conventional time labels have been attached to an infostate representing an observation, then they can be stored in a '*Long Term*' or '*Permanent*' memory as an ordered set of time labeled events. This set can be mapped onto the real number line for the creation of a 'timeline' or time axis in the case of space-time.

T-COMPUTERS IN THE BRAIN

T-computers detect signals and process them as infostates propagating sequentially (in space not necessarily 'in time') through the physical logic gates forming a causal network. The prime function of the T-computer is to pair the information representing an observed event with a 'time label'.

Based on the evidence for 'temporal processing' in the brain (Rao 2001), there are biological T-computer components that function in the same way as the idealized T-computer model described above. The brain receives information from the senses. In order to identify its causal relationship to other events it needs to time label this information and store it in a working memory.

Recent fMRI evidence (Rao 2001) implicates the *right inferior parietal cortex* and *bilateral premotor cortex* in the mechanism of 'attention' as well as the initial organization and storage of time labeled infostates in a 'working memory' acting as the *T-computer Stage I* in the brain. The T-computer Stage II is seen in temporal processing activities in the *right dorsolateral prefrontal cortex* where the comparison of the two time intervals takes place. The time labeled infostates created in Stage I, including placement of time labeled infostates in memory, are accessed and compared in Stage II in order to determine which of two sequential intervals was 'longer' and therefore determining a 'time output' in the form of a 'response' by the subjects.

This may be the site in the brain where the common conception of the 'time' (as a 'time difference') for an event or between events originates and in some sense where time first emerges in consciousness as an abstract measure perceived 'change'. From here the brain can construct maps using the time associated with onset of events, lifetimes of events, or time intervals between events as a dimension or axis like that used in space-time. The details of this process are still under investigation and outside the scope of this paper. 'Time' differences and the information defining the order of infostates representing the observed events can be used to create temporal pointers or 'arrows of time' between 'earlier' and 'later' infostates. This is one of the possible 'outputs' of the T-computer working with consciousness to create time.

The brain receives information from the senses. In order to identify its causal relationship to other events it needs to time label this information and store it in a working memory

WHAT 'TIME' IS IT?

To answer this question one must engage the T-computer and other information processing and signal generating devices such as the vocal cords needed to 'say' the time. The computation of the difference between the time labels for any two infostates results in another 'bit' of information that we call the 'time' elapsed between the two observed events. From this perspective, 'time' does not exist a priori, but is in fact a computed measure of change. The construction of a 'direction' and 'dimension' for 'arrows of time' follows from the ordered sets of numbers or label states added to observed 'infostates' originating in unstable systems. Time is what we compute it to be using our T-computers and the time part of our space-time maps. The time we give is always referenced to some standard system whose periodic changes produce reference information by which we can

say *what the time is*.

Recognition that 'time' is created by complex systems capable of 'computing' it, may clear up 'time' related paradoxes and issues related to causality, information theory, and the 'experience' of time inside complex states of 'consciousness'.

SUMMARY

In this brief paper I have attempted to outline a new way of thinking about time. I would like to summarize by stating the following three conclusions.

1. 'Change' creates signals that carry information to other systems in space.
2. Detection of signals provides information that a T-computer can compute into time labeled infostates representing observed phenomena or events.
3. Our brain's T-computer computes 'time' and 'time differences' for events. The computed times for events can be used to build maps of change such as 'space-time'.

In the brain the T-computer 'time labeling' components are found in the right inferior parietal cortex and bilateral premotor cortex. The T-computer the computes a 'time differences', Dt , and therefore the 'time', ' t ' (for $Dt = t - t_0$, where $t_0=0$) tagged to an event.

This time can be interpreted as elapsed time between events or the lifetime of a reconfiguration process. The *ordered set of these time numbers* can be used to construct a timeline. The 'order' for these sets follows from the order of integer or real numbers following from the generator function defined by the Peano axioms of mathematics. Timelines are the basis for the time axis used in space-time. The dimension of time is the dimension of the time label, if we use a real or integer number then *dimension*=1. The direction of time is the direction of the increasing time labels.

Time is a construction of the brains signal mapping, time labeling, event storage and retrieval in memories and the T-computers ability to calculate the 'time' differences which become the 'time' (with an implicit or defined initial time of $t = 0$ for instance) component of space-time maps. The brain also constructs the *dimensions* and *directions* associated with the *space components* of *space-time*.

We project the laws of physics onto our maps as a result of our computing the relationships of causal and effect for events on our maps. Using the patterns we encode as the laws of physics, we can estimate how things change and guess how emerging configurations of matter evolve.

Many questions remain about how our brains create time from the molecular scale upward to 'consciousness' but the pioneering work of Stephen M. Rao, Andrew Mayer, and Deborah L. Harrington has opened the door to understanding the connection between the changes in an evolving universe and the time we create with our brains to measure it. The ideas I have presented here indicate that a correct conception of 'time' requires that

we understand ‘time as information’ and that time is as *real* as *information* is³.

ACKNOWLEDGEMENTS

I would like to thank Sultan Tarlaci for his persistence to write this paper. I thank Vladimir A. Petrov for ‘discovering’ my work, continued moral support and sharing his considerable wisdom with me over the last 3 years. I also thank my wife Toni, and the rest of my family and friends for their patience. All are blameless for my errors. *Ad Astra, Ab Intra...*

REFERENCES

1. Stephen M. Rao, Andrew Mayer, and Deborah L. Harrington, The evolution of brain activation during temporal processing. *Nature Neuroscience*, 2001; 4:317-323.
2. Hans Reichenbach. *The Direction of Time*. Edited by Maria Reichenbach, Dover Publications, Inc., Mineola, NY, 1999.
3. Scott M. Hitchcock. *The Creation of Time from Substance and Space*. Accepted June 2002 for publication in the *Space-time and Substance International Physical Journal* at <http://spacetime.narod.ru/>
4. Scott M. Hitchcock. *Time and Information: From Feynman Diagrams to Feynman Clocks and Beyond*. 2001. Available at LANL <http://xxx.lanl.gov/abs/quant-ph/0111025>.
5. Scott M. Hitchcock. *Feynman Clocks, Casual Networks, and Hierarchical Arrows of Time in Complex Systems From the Big Bang to the Brain*. 2000. Available at <http://xxx.lanl.gov/abs/quant-ph/0010014>
6. Scott M. Hitchcock. *Quantum Clocks and the Origin of Time in Complex Systems*. 1999. Los Alamos National Lab, LANL e-Print Archives <http://xxx.lanl.gov/abs/gr-qc/9902046>.
7. J. B. Priestley. *Man and Time*. Crescent Books, London, UK, 1964. Page 64 “*No change, then, no Time*”.
8. Martinus Veltman. *Diagrammatica: the Path to Feynman Diagrams*. Cambridge University Press, UK, 1995. See Appendix D, pages 243-244.
9. Michael A. Nielsen and Issac L. Chuang. *Quantum Computation and Quantum Information*. Cambridge University Press, UK, 2000.



NEUROSCIENCE | QUANTUM PHYSICS

Copyright ©2003

³ “I could be wrong, I could be right...may the road rise with you...” from the song ‘Rise’ by P.I.L.